

# INSTALLATION GUIDE

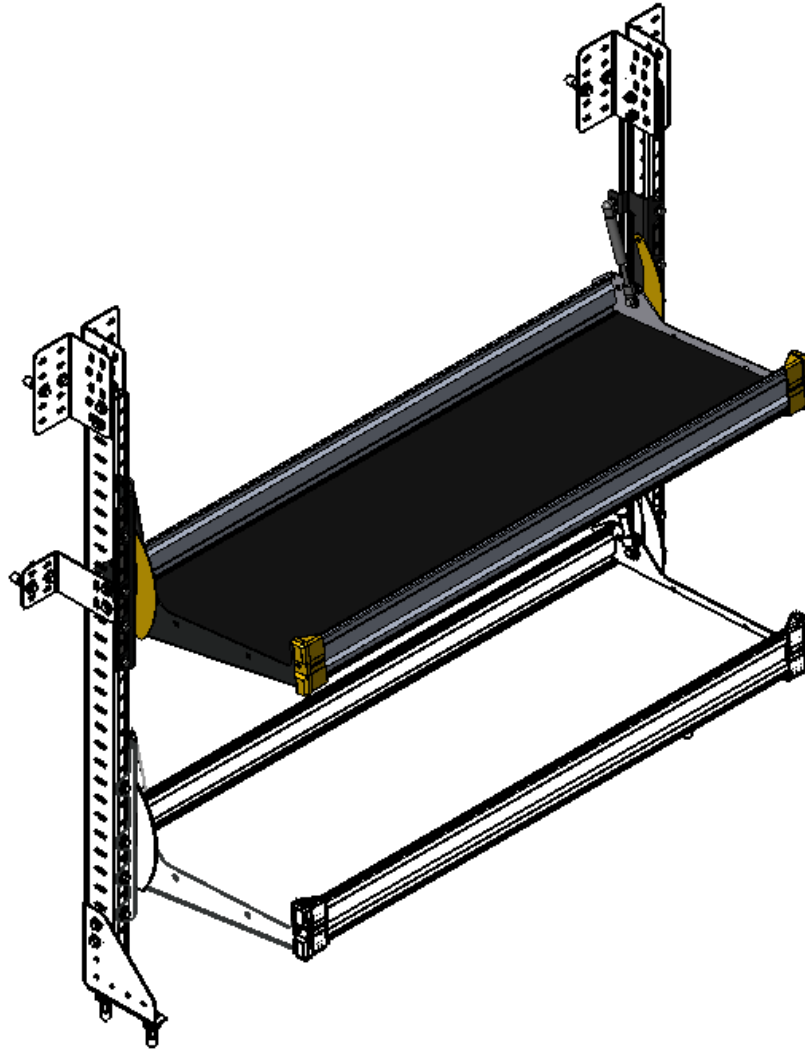

## 84-U1872 Fold-Away Shelf Tray

**RANGER**  
DESIGN

# QUICK START GUIDE

## Phase 1 - Assembly

- 1.1 Setup..... 3 - 4
- 1.2 Fold-Away Shelf Tray Assembly..... 5 - 10

# REQUIRED ITEMS

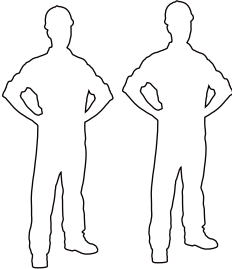

**2  
PERSONS**

- Cordless Impact
- Tape Measure
- 1/2" Socket
- 3/8" Driver Bit
- Knife

# PHASE 1 – ASSEMBLY

## 1.1 SETUP

1.1.1 Unpack components; compare with the bill of materials.

### 84-U1872

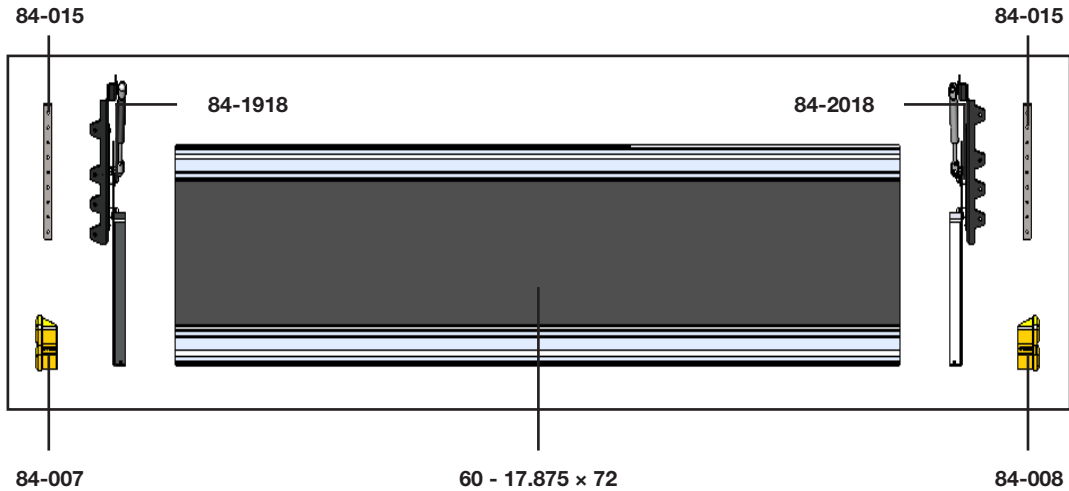

1.1.2 Verify all parts are present.

Item No.	Description	Qty.
84-007	End Cap ( Left )	2
84-008	End Cap ( Right )	2
84-015	Threaded Plate	4
84-1918	End Panel ( Left )	2
84-2018	End Panel ( Right )	2
60-17.875x72	Shelf Tray	2
94-3056	Assembly Fastener Kit	2
96-3038	Install Fastener Kit	2

94-3056



Fastener Assembly

8x



# 92-102

Screw HWH  
#14 x 1"  
ZINC

8x



#92-102 Screw #14 x 1"

4x



# 96-200

Multi-grip alum/steel  
3/16" x 1/2"

4x



#96-200 Closed Rivet

96-3038

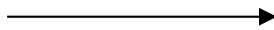

Fastener Assembly

8x



# 90-204

Hex Bolt  
5/16"-18 x 3/4"  
GR-5 ZINC

8x



#90-204 Hex Bolt 5/16" x 3/4"

8x



# 98-116

Flat Washer  
5/16"  
ZINC



#98-122 Lock Washer

8x



# 98-122

Lock Washer  
5/16"  
ZINC



#98-116 Flat Washer

# PHASE 1 – ASSEMBLY

## 1.2 FOLD-AWAY ASSEMBLY

1.2.1 Screw the left and right end panels to the shelf tray.

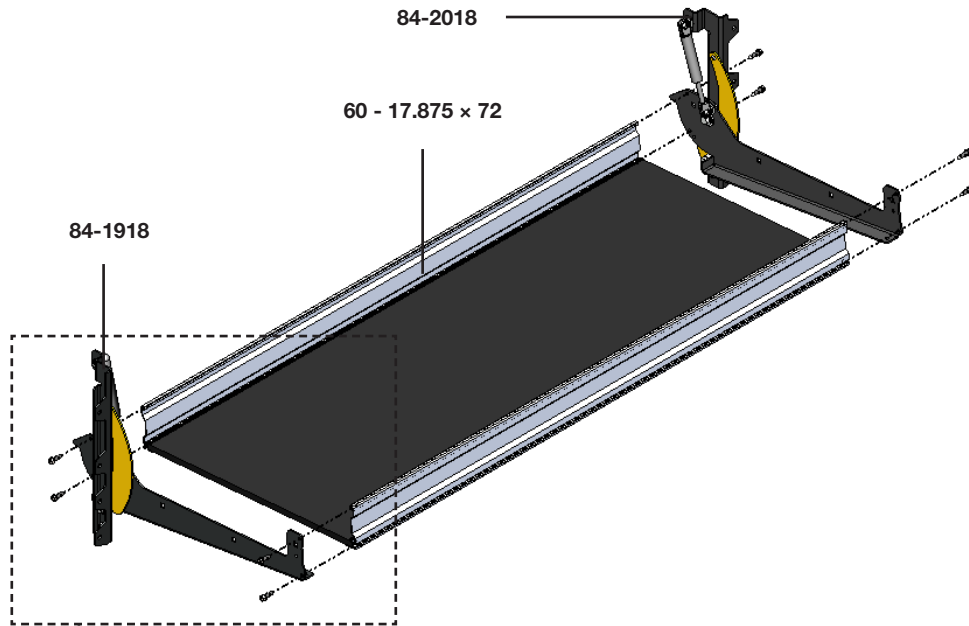

**TOOLS**

- Cordless Impact
- 3/8" Driver Bit

**HARDWARE USED**

**8x**

	#92-102 Screw #14 x 1"
---	------------------------

1.2.2 Rivet the end caps on the front edge of the shelf tray.

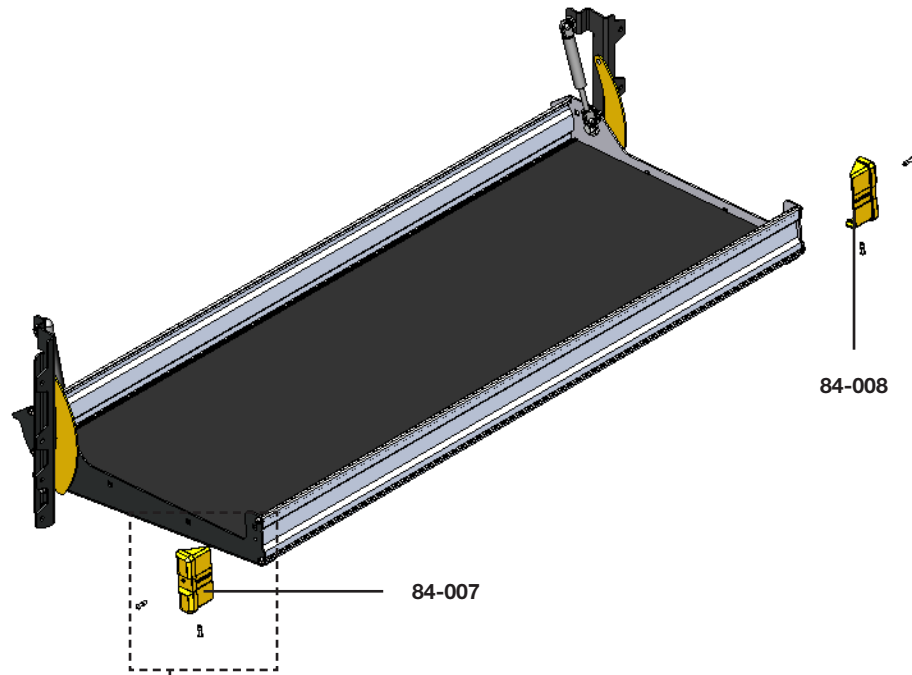

**TOOLS**

- Rivet Gun

**HARDWARE USED**

**4x**

	#96-200 Closed Rivet
---	----------------------

1.2.4 Attach the shelf trays to the posts.

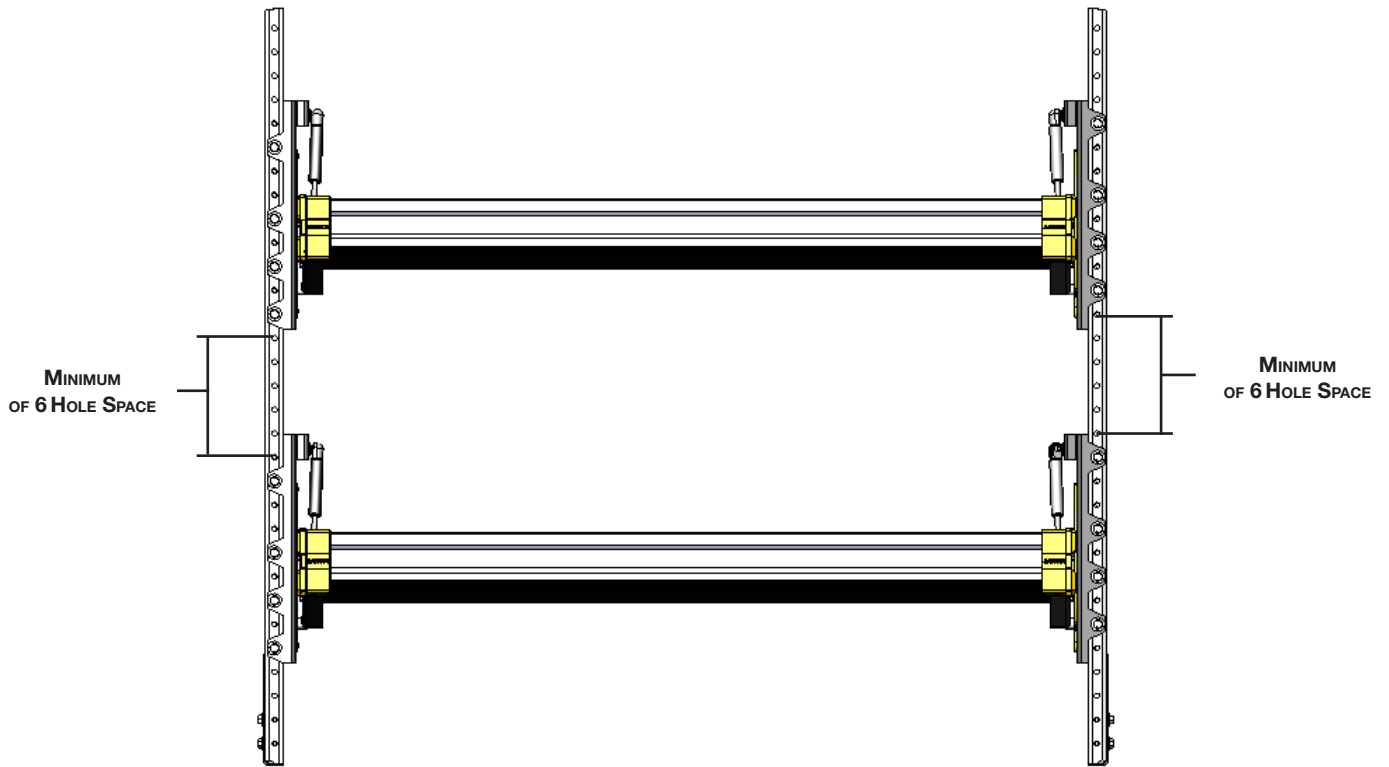



**TOOLS**

- ☐ Cordless Impact
- ☐ 1/2" Socket

**HARDWARE USED**

**16x**

	#90-204 Hex Bolt 5/16" x 3/4"
	#98-122 Lock Washer
	#98-116 Flat Washer

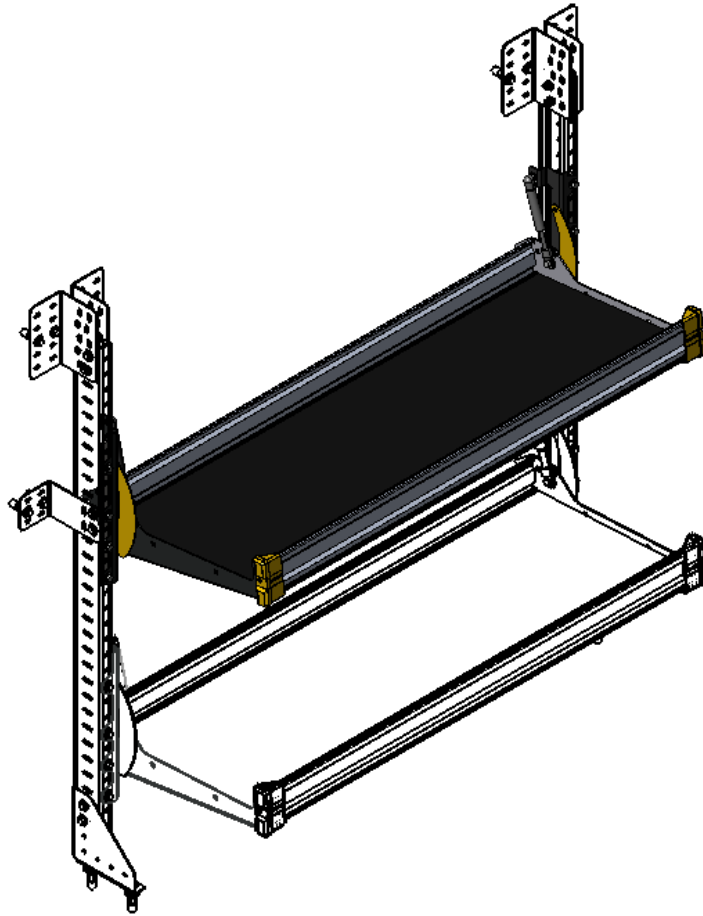

**“You have successfully installed your  
Fold-Away Shelf Tray**

**Thank you for doing business with us.”**

For any feedback or suggestions you may have, please contact: [cs@rangerdesign.com](mailto:cs@rangerdesign.com)

